

Bohrmeister®

BM250 SCR

SONIC CRAWLER RIG

PERFORMANCE

DRILLING DEPTH CAPACITY: 250 m

MAX DRILL / CASING SIZE: 300 mm

DRILL HEAD

MAKE: DIEDRICH LARGE SONIC

FREQUENCY: 0 - 180 hz

SONIC OSCILLATION FORCE: 350 kN

ROTATION SPEED: 0-200 rpm

ROTATION TORQUE: 6000 Nm

PULL UP & DOWN FORCE: 110kN

CARRIER

MOROOKA MTS2200

SPEED: 0-12 Km/hour

GRADEABILITY: 30 Degrees

MACHINE WEIGHT: 12000 kg

PAY LOAD: 10000 kg

TRACK WIDTH: 800 mm

**“THE MOST
POWERFUL
SONIC HEAD IN
THE WORLD”**



**“HANDS FREE”
BREAKOUT
CLAMP**

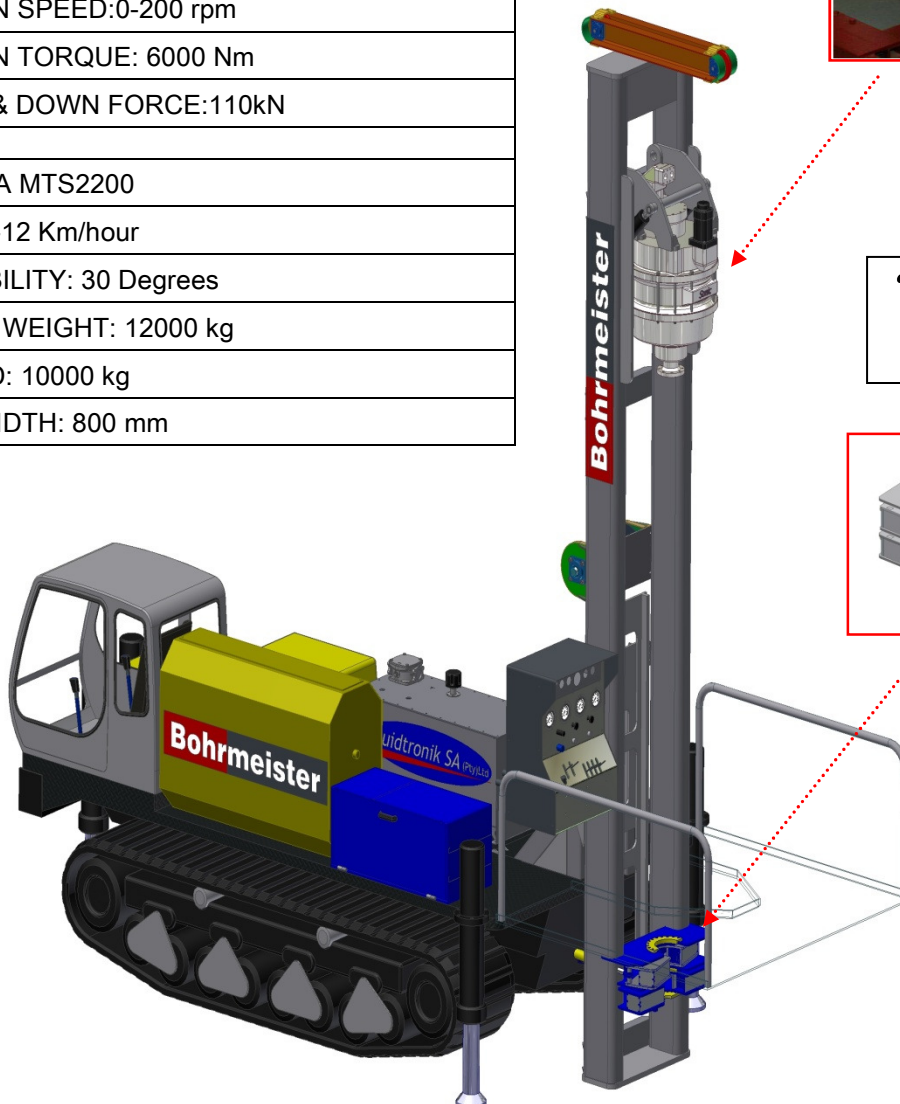
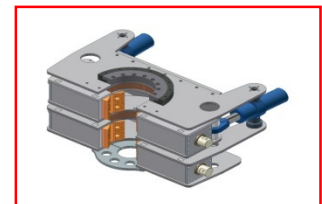

Bohrmeister®

BM250 SCR

SONIC CRAWLER RIG



**“HANDS FREE”
ROD HANDLER**

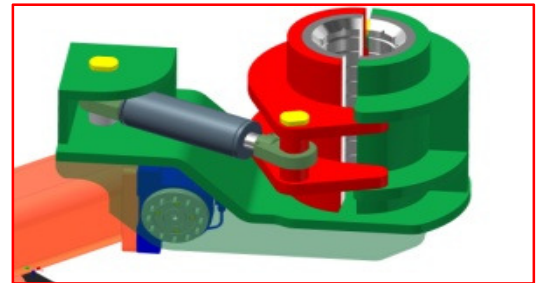

ENGINE

MAKE: CUMMINS

POWER: 330Kw @ 2100 rpm

FUEL TANK: 800 litres

HYDRAULICS

CLOSED CIRCUIT PUMP: 323l/min, 400 bar

OPEN CIRCUIT PUMP: 280l/min, 280 bar

OIL RESERVOIR: 800 litres

FILTRATION: 10µM abs

PROPORTIONAL CONTROLS: SAUER DANFOSS

RIG DIMENSIONS

LXWXH: 5.9mX2.9mX3.2m

MAST: 6m with 5m stroke

FEATURES

“HANDS FREE” ROD HANDLER

“HANDS FREE” DOUBLE BREAK OUT CLAMP

OPERATOR PLATFORM

SAFETY INTERLOCKS

WIRELINE CORE SAMPLE TECHNOLOGY

TAMPER PROOF DIESEL TANK

TAMPER PROOF BATTERY BOX